

ICSCE Compensating Stacker

The stacker interlocks products crosswise to produce a solid bundle for optimal palletizing.

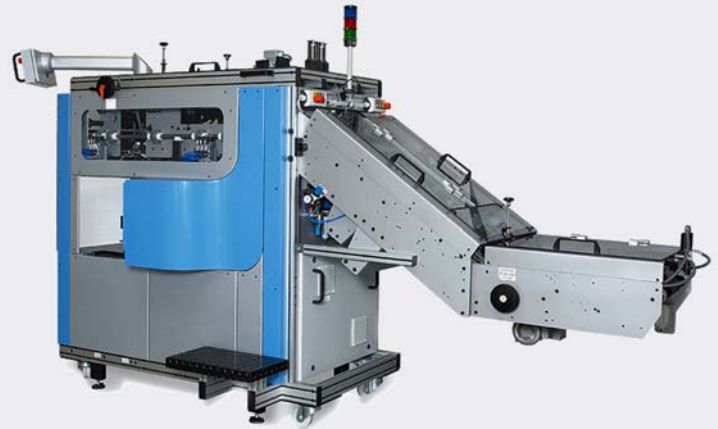

Technical Specifications

Measurements

Total height	approx. 1973 mm
Total width	approx. 1334 mm, without outlet belt
Total length	approx. 3127 mm, depending on input height
Input height	850 - 900 mm
Output height	860 - 890 mm
Batch height	max. 160 mm
Bundle height	max. 300 mm
Signature width	148 – 315 mm
Signature length	210 – 430 mm
Product diagonal	max. 510 mm, attention please

Pneumatic system

Air pressure	min. 6 bar
Air consumption	max. 1,0 Nm ³ /min., unoiled, dry air

Electrical supply data

Voltage	400 V, 3 phase, 50 Hz
Capacity	1,5 kW
Fuse	20 A slow-blow fuse
Cycle time	0,9 sec.

Production speed example for rotary press applications:

Shingle stream magazine copy stream input
Guaranteed capacity: 100.000 c/h at batches of 25 copies
Performances refer to DIN A4 products without inserts.

Production speed example for bindery applications:

- Shingle stream magazine copy input (production on 1 line; magazine strength up to approx. 120 pages.)
Guaranteed capacity: 40.000 c/h at batches of 10 copies
The shingle distance should be adjusted according to production ratio.
- Single magazine copy input (depending on weight, necessary as of 120 pages)
maximum number of pages at single copy input is 400.
Guaranteed capacity per line: 27.000 c/h with 7 copies in each batch
Performances refer to DIN A4 products without inserts.

SEGBERT

PALLETIZING & AUTOMATION

Gutenbergstraße 16
D-48683 Ahaus

Telefon +49 (0) 25 61 / 95 04-0
Telefax +49 (0) 25 61 / 95 04-20
Mail segbert@segbert.com

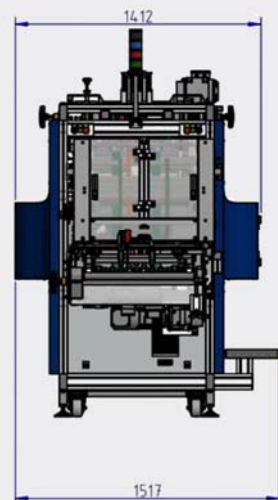
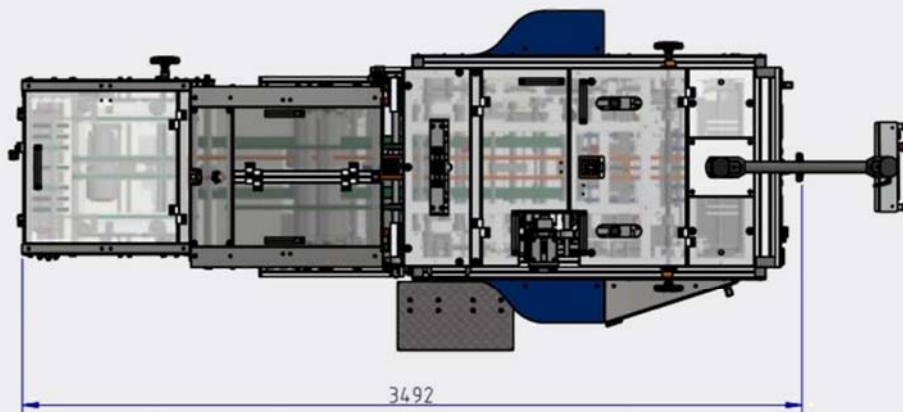
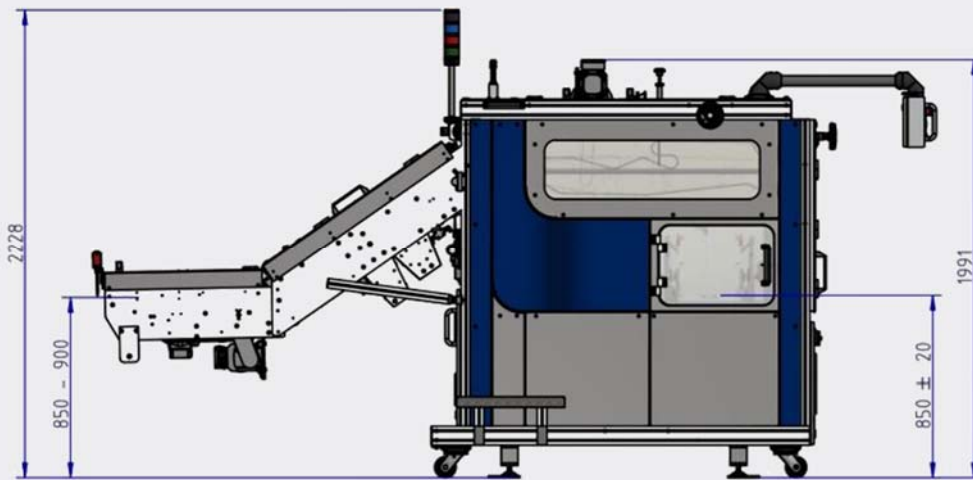

Volksbank Gronau Ahaus eG IBAN: DE33 4016 4024 0602 0192 00 BIC: GENODEM1GRN

Sitz der Gesellschaft: Ahaus Registergericht: Coesfeld, HRA 2848 UStID.: DE123788344 Steuernummer: 301/5750/0035
Komplementär: Segbert Verwaltungsgesellschaft mbH Sitz: Ahaus Registergericht: Coesfeld, HRB 4251
Geschäftsführer: Klaus Segbert

